



Technical data sheet

# A15 Polymer Concrete Channel Galvanized Grating ANR80G24



# B125 Polymer Concrete Channel Ductile Grating ANR80G25



#### SERVICE

GALCO provides custom solutions and possibilities for the contract business. Here you benefit from reliable cooperation with our technical office staff and good contact with the field staff.

CONTACT:

+353 01 424 7000



Product specifications

Product specifications	Channel	Sump unit
Material	Resin concrete	Resin concrete
Length	50 cm und 100 cm	50 cm
Width	12 cm	13.1 cm
Height	8 cm	40 cm
Weight	3.2 / 6.3 kg	15.5 kg
Nominal width	10 cm	10 cm
Slope type	Constant invert	Constant invert
Joint type	UNILINK® joint	UNILINK® joint
Fastening	Locking mechanism	Locking mechanism
Load capacity	Galvanised slotted grating Heelguard cl. A15, Cast iron slotted grating Heelguard cl. B125	
Cover gratings	Freely selectable	Freely selectable

Material properties

Channel / component body	
Polymer concrete:	polyester resin-based with mineral aggregates, additives
Compressive strength:	≥ 90 N/mm <sup>2</sup>
Bending tensile strength:	≥ 22 N/mm <sup>2</sup>
Modulus of elasticity:	ca. 25 kN/mm <sup>2</sup>
Density:	2.1 – 2.3 g/dm <sup>3</sup>
Heat resistance:	100° C (permanent loading)
Frost resistance:	-50° C
Water penetration depth:	0 mm
Water absorption:	0.05 %
Channel cover	
Cover gratings:	Galvanised slotted grating Heelguard cl. A15, Cast iron slotted grating Heelguard cl. B125

# Technical data sheet

ANR80G24 & ANR80G25



## Channel dimensions

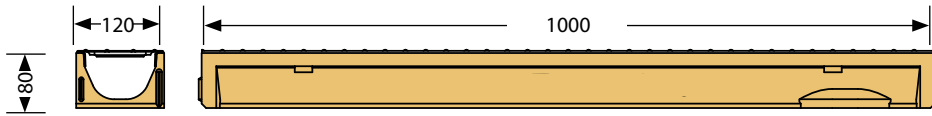

## Accessories dimensions

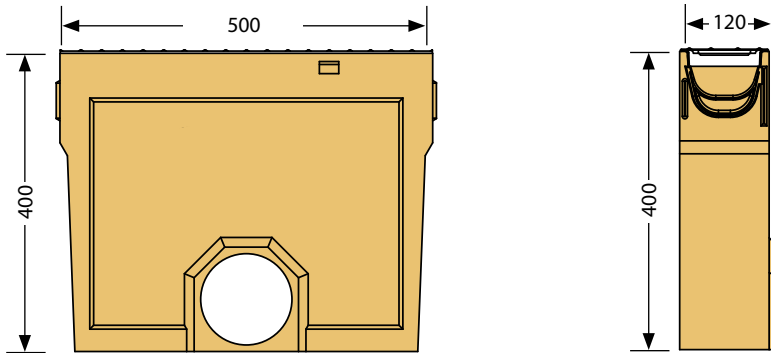

## Cover gratings



Galvanised slotted grating Heelguard  
Load capacity: A 15, Length: 50 cm, 100 cm

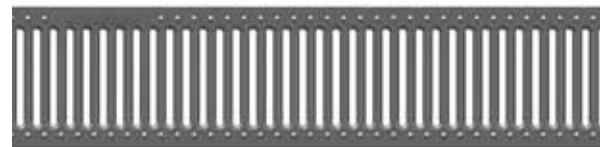

Cast iron slotted grating Heelguard,  
Load capacity: B 125, Length: 50 cm

## Technical data sheet

ANR80G24 & ANR80G25



### Galvanised slotted grating Heelguard

Article no.	EAN	Designation	Length cm	Width cm	Height cm	Weight kg
07541000	4026857029922	Channel with galvanised slotted grating Heelguard*	100	12.0	8.0	6.3
07541050	4026857029939	Channel with galvanised slotted grating Heelguard**	50	12.0	8.0	3.2
07296200	4026857029946	ump unit with galvanised slotted grating Heelguard	50	12.0	40.0	15.5

### Cast iron slotted grating Heelguard

Article no.	EAN	Designation	Length cm	Width cm	Height cm	Weight kg
07542000	4026857029953	Channel with cast iron slotted grating Heelguard*	100	12.0	8.0	10.3
07542050	4026857029960	Channel with cast iron slotted grating Heelguard**	50	12.0	8.0	5.2
07296300	4026857029977	Sump unit with cast iron slotted grating Heelguard	50	12.0	40.0	17.5

\* Channel with perforation DA/OD 110 for vertical outlet

\*\* Channel with sidewise perforations for the connection of t-junctions, elbow joints and cross-over joints





### Accessories

Article no.	EAN	Designation	Length cm	Width cm	Height cm	Weight kg
01006600	4026857000525	Foul air trap DA/OD 110				1.5
01006800	4026857000549	Pipe socket DN 100				0.2
07307100	4026857020516	Closed end cap				0.4
07308100	4026857020523	End cap with pipe socket DA/OD 110				0.8

Installation instructions

The following installation guidelines are schematic representations. These are provided as examples and are non-binding. The information provided here is based on our long-term experience in excavation and road construction as well as the state-of-the-art technology. Despite this, designers and planners are always obligated to check the products and the installation instructions for their appropriateness. The example details are simplified recommendations for execution. Constructions are to be re-created on a project-specific basis.

Important: Insert gratings for the installation.

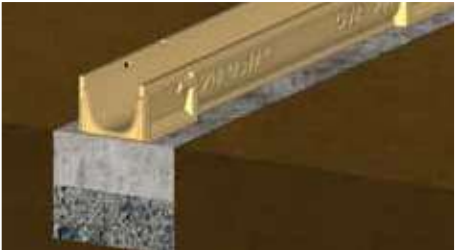
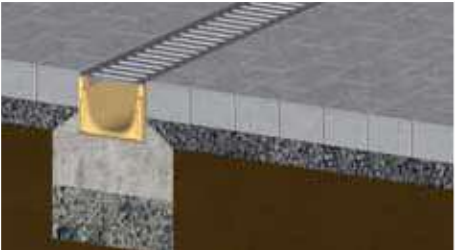
Installation instructions	
	Dig out the trench. Fill in and pre-condense the base course.
	Connect pipe connections to the pipeline and align the components evenly. Fill concrete bed.
	Fill concrete, 3 parts sand + 1 part water + 1 part cement, into the base of the trench.
	Place cover gratings on the channels.
	Position channel string, sump unit and end cap on the concrete bed.
	Install paving. The layer should end 2 to 5 mm higher than the cover grating.