

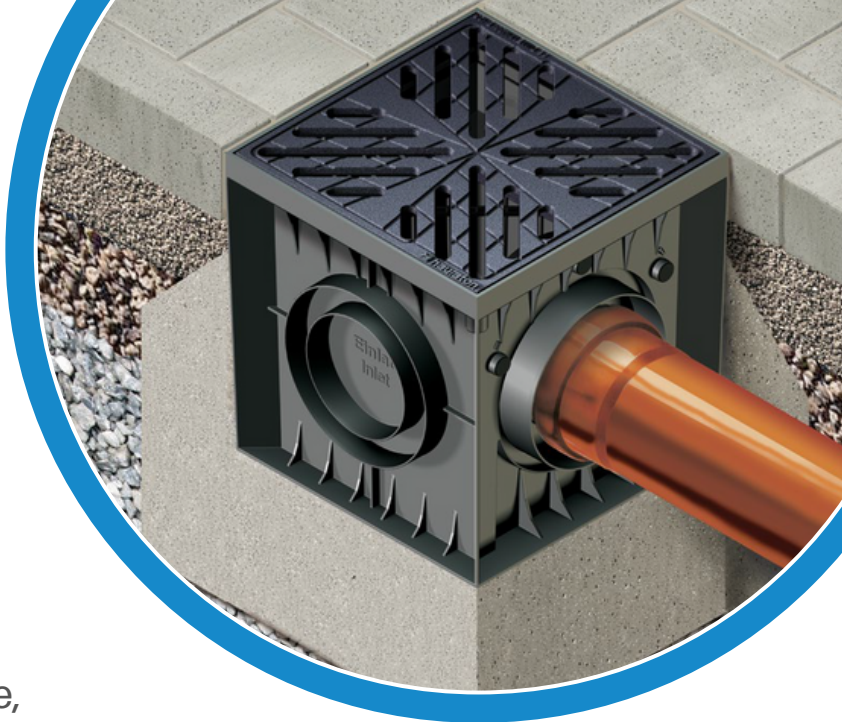

RECYFIX POINT

Point drainage for paved areas: courtyards, walkways and public squares.



PRODUCT CODE: RF32612

RECYFIX POINT 30/30, Point drainage, **class C 250**, with foul air trap, mud bucket and KG-pipe connection DN/OD 110, DN/OD 160

Construction height 300 mm with longitudinal ductile iron grating, bar distance 8 mm, screwed, black, KTL-coated

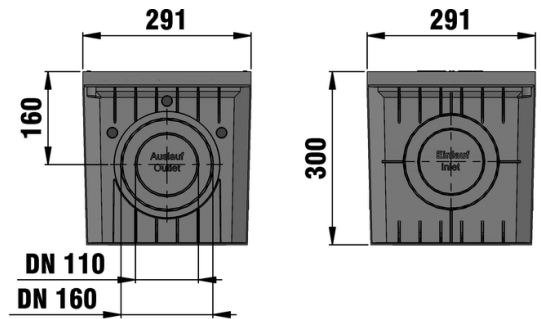

Length mm	Width mm	Height mm	Weight kg	Inlet cross-section cm ² /m
291	291	300	6.893	989.0

Your benefits with RECYFIX POINT

- Manufactured from durable and resistant modified polypropylene.
- Lightweight unit for easy transportation, handling and installation.
- Various connection options to any type of pipework.
- Gratings in ductile iron: star design or longitudinal bars and mesh grating in galvanised steel.
- Easy cleaning and maintenance: removable mud buckets prevent blockages.
- Withstands a range of temperature differences and UV radiation



Are you looking for drainage solutions for your project?

Christy McPartland

Area: Connaught & North Leinster
087 615 5565
christy.mcpartland@galco.ie



Chris White

Area: Dublin City & County
087 718 3274
chris.white@galco.ie



Michael Coady

Area: Munster & South Leinster
087 271 2951
michael.coady@galco.ie

